

# OPERATING MANUAL

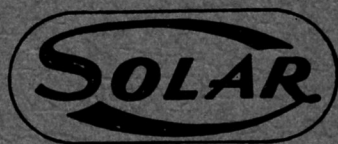

MODEL QCA  
"QUICK-CHECK"  
CAPACITOR  
ANALYZER

Edition 341

SOLAR MANUFACTURING CORPORATION  
BAYONNE ● NEW JERSEY

## SOLAR MODEL QCA CAPACITOR ANALYZER

ENGINEERS DO NOT GUESS—THEY **KNOW!** This new radio service tool tells the quality story of condensers with remarkable speed. All types are handled: paper, mica, electrolytic and air condensers.

The "Quick-Check" feature spots opens, shorts, intermittents, high power factor or high r.f. impedance without disconnecting the units under test; the set may be operating. This time-saver often eliminates the trouble so that no further tests will be needed.

Model QCA, however, is a complete analyzer. If additional tests are necessary, condensers are checked separately. Capacity measurements can be made up to 70 mfd. Tests can be made for leakage of electrolytics and for insulation resistance of paper or mica condensers. The instrument is also a useful continuity meter.

Testing under operating conditions is often the only way to spot intermittents; Model QCA does it readily. The "Quick-Check" feature works equally well whether the condenser is fully connected in the circuit, or has one or both leads disconnected, or the condenser may be shunted by an inductance or resistance. Only Model QCA contains these modern features in a tester which all can afford.

Test procedure is quick and simple.

## **MODEL QCA-1-60 CAPACITOR ANALYZER**

### **Power Line Connections**

The Solar Model QCA-1-60 Capacitor Analyzer is designed for use on 110 volts, 50-60 cycles. It should not be connected to power lines which supply other voltages or frequencies. Proceed with measurements according to instructions described in this manual.

## **MODEL QCA-2-U CAPACITOR ANALYZER**

### **Power Line Connections**

The Solar Model QCA-2-U is a universal instrument which can be operated from power lines rated at 120, 165 or 240 volts, 50 to 60 cycles.

To place the QCA Analyzer into operation remove the small metal plate in the back of the cabinet and insert the plug in the jack corresponding with the available line voltage.

## **OPERATING INSTRUCTIONS**

### **SOLAR CAPACITOR ANALYZER**

Model: QCA-1-60	110 volts	50-60 cycles
Model: QCA-2-U	120, 165, 240 volts	50-60 cycles

### **GENERAL**

The Solar QCA Capacitor Analyzer provides radio service engineers and laboratories with a capacitor analyzer that combines in one instrument a convenient and simple method of making a complete analysis of condensers under conditions of operation, static or dynamic.

The performance characteristics of radio and video receivers have imposed requirements which can be maintained only by the use of high quality component parts. These parts, especially condensers, must have the proper electrical characteristics to perform their designated functions properly, if satisfactory results are to be obtained from receivers.

Condensers have a detrimental effect on reception long before they become entirely defective. The problem of determining the quality or operating efficiency of a condenser requires a complete analysis of its constants.

In this instrument condensers may be tested for capacity, leakage, insulation resistance, power factor, opens, shorts, intermittents, and r.f. impedance. Also with the full development of the Quick-Check features plus the Wien Bridge, we find it possible to present an instrument which will give every qualitative and quantitative measurement of capacitors necessary in modern servicing of a simple indication.

Model QCA tells the performance story of all types of paper, mica, electrolytic, trimmer and air condensers. Checking for quality is done under conditions of either static or dynamic performance; the condenser under test may be operating in a circuit, or it may be disconnected.

Accurately calibrated markings on the panel are provided for convenient measurements of capacity. These tests are made on a Wien Bridge with three ranges by multiplying the direct scale reading by the bridge constant.

The power factor of all types of electrolytic capacitors is indicated by the degree of opening of the electron-eye.

The capacity range of the instrument is from .00002 mfd. to 70 mfd.

Only two terminals are used for all tests. The switch in the QCA Analyzer automatically connects the unit under test into the proper circuit.

The leakage test part of the instrument consists of a D.C. power supply and electron-ray tube. A selector switch is provided with voltage settings covering practically all electrolytic condensers which may be encountered in the field.

The insulation resistance range of the instrument provides quick and positive means of determining faulty condensers.

The quick-check feature of the QCA consists essentially of a complex balanced radio frequency oscillator, an electron-ray tube indicator and a source of power.

The Quick-Check system is arranged to permit easy and positive determination of opens, intermittents, shorts, and high r.f. impedance under static or dynamic conditions. The condenser under test may be operating in the circuit, or it may be disconnected.

The instructions which follow specify certain limits which have been set as standards to be used as a guide in judging satisfactory condensers. These limits were set arbitrarily on the basis of our years of experience with condensers. In general, condensers which meet these specifications will be found satisfactory in radio set operation, while those rejected will interfere with satisfactory operation of the circuit in which they are used.

On the other hand, it is well known that condensers used in certain specific circuits may be more, or possibly less critical with respect to their electrical constants than our limits indicate. These exceptional cases can be handled best by intelligent use of the capacitor analyzer, after careful and thorough study of all the accompanying instructions.

### **QUANTITATIVE MEASUREMENTS**

In order to make quantitative measurements at least one terminal of the condenser must be disconnected from the circuit, or the condenser may be entirely disconnected.

To make the instrument ready for test, the following procedure should be followed:

1. Insert the test leads.
2. Connect the line plug to the power outlet and switch to "On".

Allow one minute for tubes to heat up.

## CAPACITY MEASUREMENTS

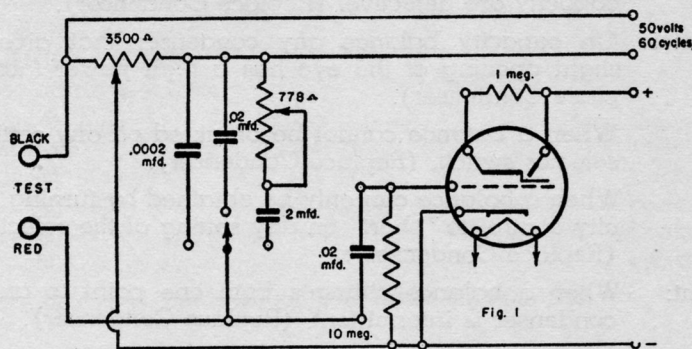

The test section is a special Wien Bridge which consists of potentiometer "R2", standard capacitors C7, C8, C9, and the unknown condenser connected across the test terminals. The 60 cycle source voltage is obtained from a winding on the power transformer. A 6G5/U5 is used as an amplifier and null indicator.

To make the instrument ready for capacity and power factor checks, proceed as follows:

1. Set the selector switch on the desired range as described below.
2. Proceed with testing by connecting the test leads across the condenser under examination.
3. Rotate the capacity control slowly from right to left until the shadow angle on the electron-eye is at a maximum. This is the "Balance Position". Capacity readings are given directly, taking into account the factor shown by multiplier switch.

Capacity Range	Setting for Range Switch	Multiply Scale Reading By
.00002 to .002 mfd.	.0001	.0001
.002 to .2 mfd.	.01	.01
.2 to 70 mfd.	1.0	1.0

- Off Capacity: Condensers that measure more than 30% under their rated capacity are defective. (Replace Condenser).
- Power Factor: On capacity balance any condenser that gives only a slight opening of the eye has a high power factor. (Replace Condenser).
- Open: When a balance cannot be obtained on any setting of the selector switch. (Replace Condenser).
- Shorted: When a balance can only be obtained by turning the capacity control to "short" on any setting of the selector switch. (Replace Condenser).
- Intermittent: When a balance changes from one point to another the condenser is intermittent. (Replace Condenser).

### LEAKAGE TEST ON ELECTROLYTICS

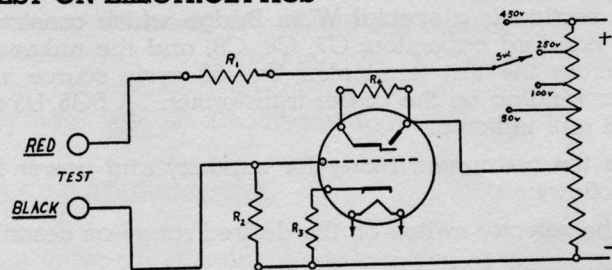

FIGURE 2

Figure 2 is a simplified circuit diagram of the electrolytic leakage test circuit. The desired D.C. Voltage, selected by switch "S", is impressed across the condenser under examination. The leakage current of the condenser is given directly as either good, bad, or doubtful by the electron-ray tube.

To make the instrument ready for leakage tests, proceed as follows:

1. Rotate the capacity control knob to the extreme left past the leakage position until the switch snaps on.
2. Set the selector switch on the desired range as described below.

3. Proceed with testing by connecting the test leads across the condenser under examination.
4. Observe polarity.  
Positive—red  
Negative—black

D.C. Working Voltage of Condenser	Place Selector Switch at	Place Capacity Control to extreme left past
0—100	50	Leakage
100—250	100	Leakage
250—450	250	Leakage
450—600	450	Leakage

The results are given as either good, bad, or doubtful.

Good:

**From Shadow Overlapping To Eye Just Closing**

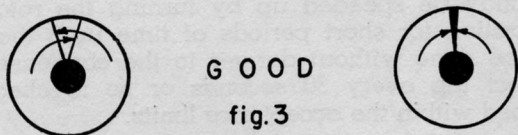

G O O D

fig. 3

The eye closes. The leakage is less than 2.5 ma.

Doubtful:

**Shadow Limits : Eye Just Closing To  $\frac{1}{16}$ " Open**

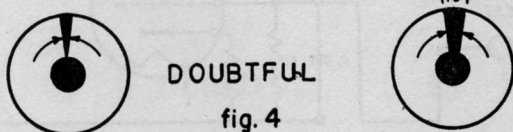

DOUBTFUL

fig. 4

The eye remains slightly open. From  $\frac{1}{16}$ " opening to the point where the eye just closes. The leakage current in this case covers a range from 2.5 ma. to 3.5 ma.



Bad:

Shadow Limits : From  $\frac{1}{16}''$  To Eye Open Full

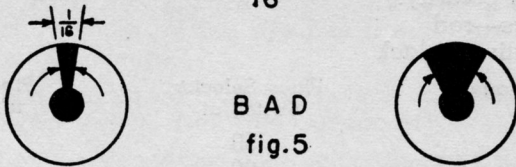

The eye opens more than  $\frac{1}{16}''$ . The leakage current in this case is greater than 3.5 ma. (Replace condenser).

The time required for the leakage to drop within the acceptance limits depends upon the length of time the capacitor has been out of service.

Electrolytic condensers which have been out of service for long periods of time may require 20 to 30 minutes for the leakage to drop below the required value; that is, for the shadow angle to come to rest. Tests on such condensers may be speeded up by turning the rotary switch to a higher voltage position for short periods of time until the condenser reforms. This can be done without danger to the condenser by switching back to the correct tap every 30 seconds or so to check whether the leakage has dropped within the acceptance limits.

#### INSULATION RESISTANCE CHECKS

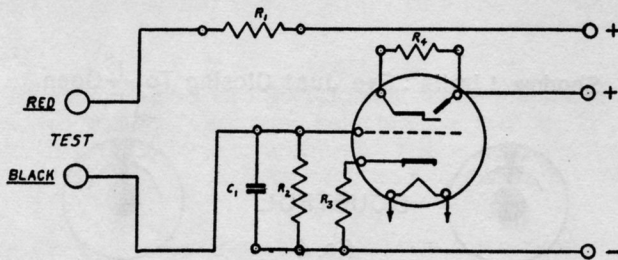

FIGURE 6

The indication of quality is given directly by the electron-ray tube. On low capacity units like mica condensers, the reading can be taken

almost immediately. On high capacity units it will be necessary to wait until the condenser becomes charged before the results are taken. This takes about one minute for a 1 mfd. condenser. The difference in time between low and high capacity condensers is due to the difference in charging rate. The high capacity unit takes longer to charge.

The condensers are checked for insulation resistance at 500 volts D.C.

To make the instrument ready for insulation resistance checks, proceed as follows:

1. Set the selector switch on range "Ω".
2. Rotate the capacity control knob to the extreme left past the leakage position until the switch snaps on.
3. Proceed with testing by connecting the test leads across the condenser under examination.

The results are given as either good, doubtful, or bad.

Good:

**From Shadow Overlapping To Eye Just Closing**

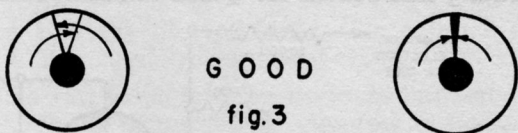

The eye closes completely. The insulation resistance is greater than 150 megohms.

Doubtful:

**Shadow Limits : Eye Just Closing To  $\frac{1}{16}$ " Open**

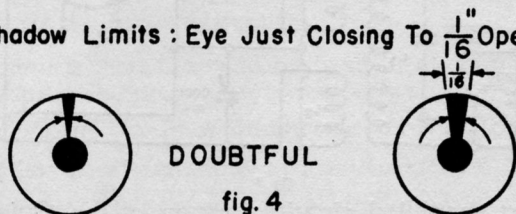

A slight opening of the eye. From  $\frac{1}{16}$ " to the point where the eye just closes. The insulation resistance value in this case covers a range from 100 to 150 megohms.

Bad:

Shadow Limits : From  $\frac{1}{16}$ " To Eye Open Full

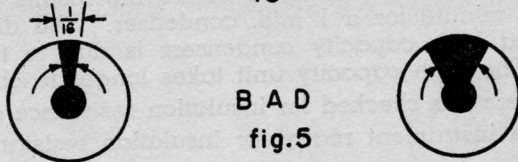

The eye opens more than  $\frac{1}{16}$ ". The insulation resistance value in this case is less than 100 megohms. (Replace Condenser).

The leakage check on paper, mica, and trimmer condensers is made in the manner described.

**Note:** In the case of coupling condensers only those showing "good" should be used. On the other hand, condensers showing "doubtful" will be found satisfactory for most applications.

### QUALITATIVE MEASUREMENTS Operating Instructions for Quick-Check Section

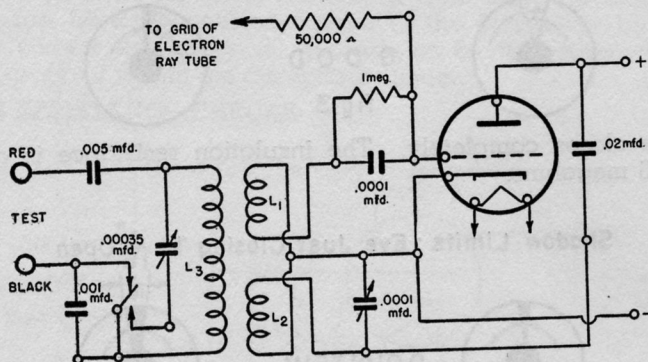

Fig. 7

Figure 7 is a simplified circuit diagram of the Quick-Check section of the instrument.

It is essentially a balanced radio frequency oscillator, a visual indicator in the form of an electron-ray tube and a source of power. The oscillator

system is arranged to permit easy and positive determination of capacitor quality.

With qualitative checking it is not necessary to disconnect the condenser from the circuit. The condenser under examination can be checked in the set under the actual operating conditions with the set switched on, or with the set switched off, or with the condenser disconnected from the circuit if desired, although this is not necessary. The instrument is so designed that the indication is definite and instantaneous even though the condenser is shunted by an inductance or resistance. These factors do not detract from the accuracy of the measurements. The qualitative range of the instrument extends from 70 mmf. to 50 mfd.

Its features include a determination of: intermittents, opens, shorts, r.f. impedance, and high power factor.

To make the instrument ready for test, the following procedure should be observed:

1. Set the multiplier Switch on the position marked "D".
2. Revolve capacity dial pointer to the extreme clockwise position until it rests at the position marked "short".
3. Insert the test leads into the tip jacks marked "test". The red plug should be connected into the red jack and the black plug into the black jack to obtain the correct polarity.
4. Connect the line plug to the power outlet and throw the line switch to the "On" position. About one minute should be allowed for the tubes to heat up.

The instrument is now ready to be used in making tests on capacitors in a receiver circuit. The procedure to be followed is:

1. Test for "opens", or intermittently open capacitors.
2. For shorted or intermittently shorted capacitors.
3. RF and power factor checks for electrolytic capacitors.

**Opens:** Before the test leads are connected across the capacitor to be tested, it should be noted that the electric eye is at its maximum opening, having a shadow angle of about 90°. The test probes

are now connected across the unknown capacitor. If there is no change in the shadow angle, this indicates that the capacitor is "open".

**NOTE:** TEST INDICATION IS GIVEN AT THE MOMENT WHEN LEADS ARE CONNECTED ACROSS THE CAPACITOR.

The "open" test can be made even though the condenser is shunted by an inductance or resistance, and the accuracy of the measurement will not be affected.

**Intermittents:** If the shadow flickers, that is, opens and closes, this denotes an intermittent open connection.

A note of caution should be introduced at this point. The operator should be sure that the test leads are securely plugged into the jacks and alligator clips securely fastened to the capacitor terminals; otherwise, the test may indicate an intermittent capacitor when the fault is the result of a poor connection.

**Shorts:** If the eye closes at the moment when the test leads are connected across the condenser, this is a positive indication that the capacitor is not open. It is now necessary to determine by another test whether the condenser is shorted.

The slide switches marked "L" and "H" are provided for this test. If it is known that the unknown capacitor is less than .003 mfd., then slide switch "L" is pushed. If the capacitor is above this value, slide switch marked "H" is used. If the electric eye opens completely when the proper button is pressed, then the capacitor is shorted. If the eye remains stationary, closes slightly, or opens slightly, the condenser is not shorted.

A double check is necessary when making the short circuit test when the value of the capacitor under examination is in doubt. First push switch "L" then switch "H" and if the condenser is shorted, the eye will open completely in each case. If the eye does not open completely in **each** case, the condenser is not shorted even though it shows short when one of the buttons is depressed. The short circuit test is effective even though the condenser is shunted by an inductance or resistance.

Be sure the slide switches are pushed all the way over in making the short circuit test. It sometimes happens that the eye will flicker as the switch is pushed over. This is a result of changing the internal circuit connections, and is not indicative of an intermittent short on the capacitor.

When the switch is held over and the eye shadow opens and closes, then this is a positive indication that the condenser is intermittently shorted.

Now a word in general about intermittent condensers, supplementing the information previously given for intermittent opens and intermittent shorts.

An intermittent condenser may be the result of a pressure contact only, between the terminals and the condenser section proper, and this connection will be broken if the unit is subjected to mechanical vibration or temperature changes.

It is suggested that in checking for intermittents that the condenser be moved back and forth slightly to show up such pressure contacts.

In case this mechanical test does not show up the fault, the Quick-Check leads can be left connected across the capacitor and the receiver placed in normal operation until it has reached operating temperature.

If the unit becomes intermittent as a result of temperature, the electric eye will flicker.

The accuracy of this check will not be affected even if the condenser under test is shunted by an inductance or a resistance.

#### **R.F. IMPEDANCE AND POWER FACTOR**

The Quick-Check offers a convenient method for indicating electrolytic capacitors which have high power factor and high r.f. impedance. It sometimes happens that in checking an electrolytic condenser there will be sufficient capacitance in the circuit to indicate that the unit is okay. However, the power factor will be so high as to make the capacitor perform unsatisfactorily in the circuit.

The power factor can be detected with the Quick-Check, thus: The test probes are connected across the electrolytic capacitor under test and if the condenser is not open, the eye will close. If slide switch "L" is then pushed over, the shadow angle of the electric eye will indicate power factor. If the eye does not open completely, the condenser is defective either because of high power factor or high r.f. impedance. If the condenser is then shunted with a .1 mfd. tubular paper condenser and the circuit disturbance is cleared up, this is an indication of high r.f. impedance. If the circuit disturbance is not cleared up, and particularly if high hum is noted, then the capacitor has high power factor. In either case, the capa-

citor should be replaced. A further check is to measure the capacitance with the Wien Bridge and if the value is substantially below the capacitance stamped on the case, this is a further indication of an unsatisfactory unit.

In certain cases some electrolytic condensers and filter type paper units show up as opens (no change in the shadow angle) when they are actually okay. This is due to the fact that the inductance of these condensers is particularly high. Condensers with long leads will have comparatively high inductance values. Therefore, in order to check these properly, it is necessary to make quantitative checks on those particular units.

Condensers with high values of inductance are not necessarily defective. They may or may not cause instability depending upon the circuit design in which they are used. This will have to be left to the judgment of the person making the checks.

#### **CONTINUITY CHECKS**

Continuity checks may be performed with the instrument. Two methods of procedure are suggested.

One method makes use of the leakage check feature of the instrument.

To make this check for leakage:

1. Rotate the capacity control knob to the extreme left past the leakage position until the switch snaps on.
2. Set the selector switch on the "50" position.
3. Proceed with testing by connecting the test leads across the circuit or circuit element under examination. If there is a complete circuit the eye will open slightly. If the eye closes, then the circuit is open.

The voltage across the test probes in this check is about 40 volts D.C.

The other method for continuity checking is to take advantage of the bridge circuit of the instrument. In this test, the capacity dial pointer is rotated to the extreme clock-wise position of the dial which is marked "short" and the range switch is set for the .01 position. The test probes are then connected to the circuit or component under examination. If the circuit is complete, the eye will open; if the circuit is open, then the eye will remain closed.

The voltage used in this test is 60 cycles A.C. and an inductance connected across the probes will show up similar to a resistance.

The degree of opening of the eye or the size of the shadow angle will give an indication of whether the circuit is completely shorted or whether there is resistance in the circuit.

Under complete short circuited conditions, the eye will open completely, and the shadow angle will be approximately  $90^\circ$ . If there is any resistance in the circuit, the shadow angle will be reduced. The degree of opening of the shadow angle is an indication of the magnitude of the resistance in the circuit.

#### **READJUSTMENT OF THE QUICK-CHECK SECTION OF THE QCA ANALYZER**

The Quick-Check section of the analyzer sometimes may go out of adjustment due to rough handling in shipment.

Improper adjustment will be indicated by one or more of the following conditions:

1. The eye is closed or partially closed even when no condenser is connected across the test clips.
2. Lack of sensitivity. The eye will give no indication on low capacities and in some cases no indication on any capacity.
3. Too sensitive. When a condenser is connected across the test lead, the eye will close in the normal manner but will not open when the condenser is removed.

The analyzer can be readjusted very simply by following the following procedure:

Set the analyzer for dynamic checking and insert the test leads into the tip jacks. Do not short the test clips together.

Now adjust the trimmer condenser through the elongated hole in the bottom of the analyzer case so that the eye just opens.

Tightening the trimmer will cause the eye to open.

Loosening the trimmer will cause the eye to close.

Proper adjustment of the analyzer will be realized when the following conditions are fulfilled.

First, the eye will be completely open when no condenser is connected across the test clips.

Secondly, the eye will practically close when a 70 to 100 mmf. condenser is connected across the test clips.



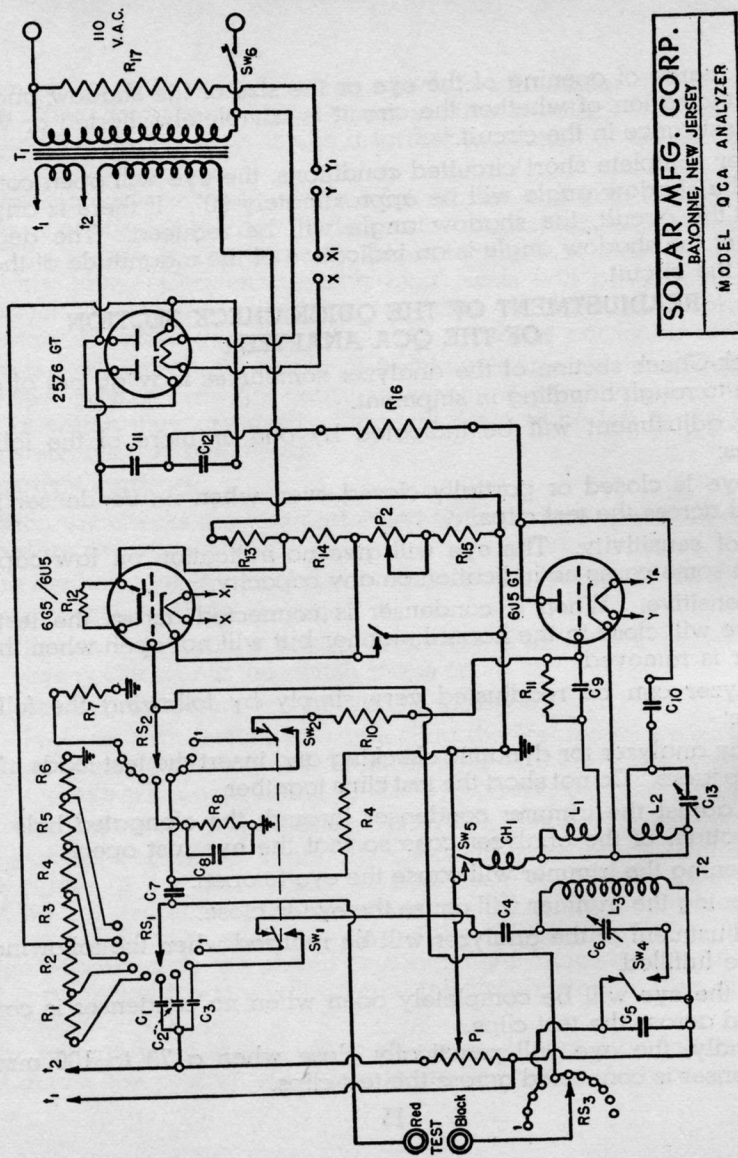

**SOLAR MFG. CORP.**  
 BAYONNE, NEW JERSEY  
 MODEL QCA ANALYZER